

Design and Development of 1-kW SSPA for UHF Band Wind Profiler

Shoma kamle, S.N.V.Satyanarayana, Anitha Daniel, R.Ranga Rao

Radar Development Area, ISTRAC, ISRO, Bengaluru

Shoma_chandorkar@istrac.org, snvsatya@istrac.org

Abstract:

This paper discusses the design and development of 1- kW solid state power amplifier at 430 MHz, using high power LDMOS transistor. This SSPA is designed to operate in class-AB mode and delivers 1- kW pulsed power with an efficiency of 65% to 70%, up to 16% duty ratio Design includes impedance matching using transmission line transformers, for efficient input and output power coupling, for broad band applications. Impedance matching circuit was realized with micro strip lines and lumped elements.

I. INTRODUCTION

Development of Solid State Power amplifier has proved as reliable power source for phased array radar technology. Push pull LDMOS, MRF6VP41KH (Free scale semiconductor Co.) transistor operating with 50V is adopted for generation of 1-kW power with maximum of 16 % duty ratio. The two push-pull sections of the device are completely independent of each other inside the package. Using single LDMOS device for 1-kW RF power generation eliminates the need for power divider and combiners for two or more devices and also reduces the complexity of circuit.

To implement the LDMOS as a RF power amplifier, the chip is soldered on Arlon ($\epsilon_r=2.55$, 0.03") PCB board. Push-pull amplifiers require splitting of the RF signal at the input along with the reciprocal operation i.e. the need to recombine the output. The balun splits the signal into halves with equal amplitude and with a 180° differential phase shift across all frequencies.

Even though power amplifier was realized with three stages adding up to a net gain of 62 dB, this paper

describes the design and realization aspects of final stage alone. Final stage is realized with MRF6VP41KH push-pull device, which delivers 1-kW power output with a gain of 21 dB.

II. DESIGN OF PUSH PULL BROADBAND POWER AMPLIFIER

Schematic is divided into five sections from left to right input balun, input matching section, and power LDMOS, output matching network, output balun as shown in Fig.1. Balun is made of 25 ohm semi rigid coaxial cable. In order to avoid resonance, length of coaxial cable is kept $< \lambda_{min}/8$. The 25 Ω coaxial baluns transform the unbalanced 50 Ω input and output into impedances that are easier to match for the transistor. Impedance matching circuit was realized with micro strip lines and shunt capacitors using smith chart application tool. Design is simulated in AWR's microwave office software. Good agreement is found in simulated and measured results.

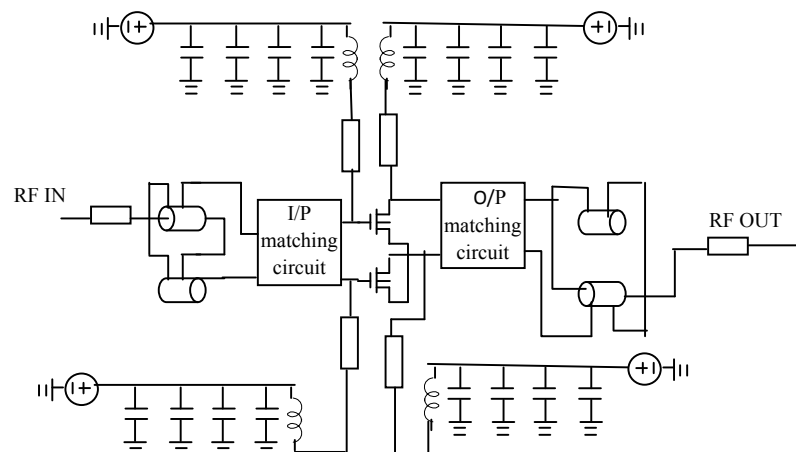

Fig.1 Schematic of power Amplifier

III. 1-KW MODULE FABRICATION AND MEASUREMENTS

The amplifier was fabricated on Arlon Copper Clad (250GX-0300-55-22) substrate of 0.030" height and dielectric constant (ϵ_r) of 2.55, which is mounted on an aluminum block with a copper insert for efficient heat transfer from transistor package to heat sink. Push pull device carefully greased with thermal compound between flange and heat sink and then bolted down with screws to an appropriate torque. Proper mounting of the device on the heat sink will ensure efficient heat transfer and hence protects the device from thermal failures.

Fig. 2(a) shows a thermal image of the 1-kW module, taken with fluke thermal imager (Ti32) while in operation at 16% duty. Measured hotspot temperature is 93.2° C. Thermal resistance of the device (θ_{jc}) being 0.03 ° C/Watt, thermal imager measurement indicates junction temperature to be 100 ° C maximum. Rest of the PCB and components are all in safe operating temperature range.

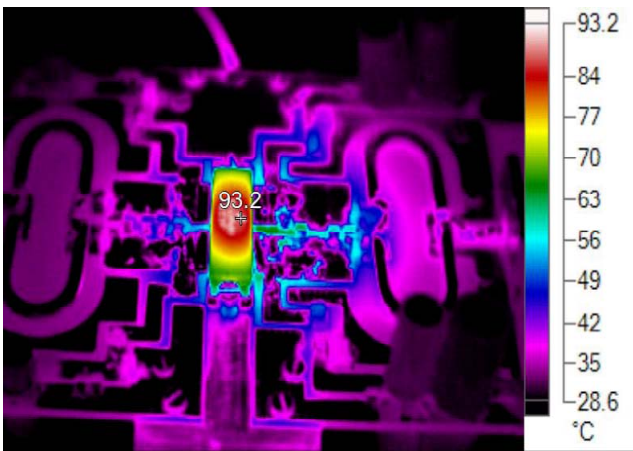

Fig. 2 (a) Thermal image of 1-kW amplifier using a thermal imager

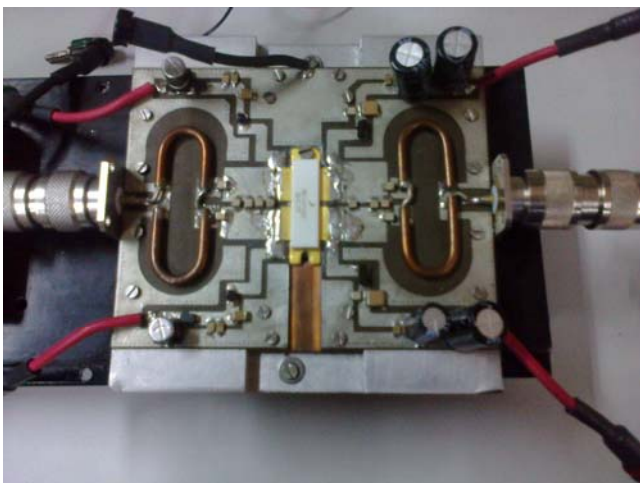

Fig. 2 (b) Photograph of fabricated 1-kW module

IV. MEASUREMENTS AND TEST RESULTS:

Power amplifier, along with heat sink mount, was subjected to tuning and measurement of key parameters. All measurements are carried out with a calibrated test setup and an optimally adjusted gate bias to draw minimum quiescent current in class-AB operation.

Power amplifier was tested with full load of 16 % duty and 1-kW output power for power added efficiency (PAE) measurement. PAE at 430 MHz was measured to be 65-70%.

Measured parameters include linearity represented in Fig.3(a), frequency response shown in Fig 3(b), pulse spectrum for different pulse widths, harmonics, and time domain measurements. Measured rise time and fall time is less than 50nsec.

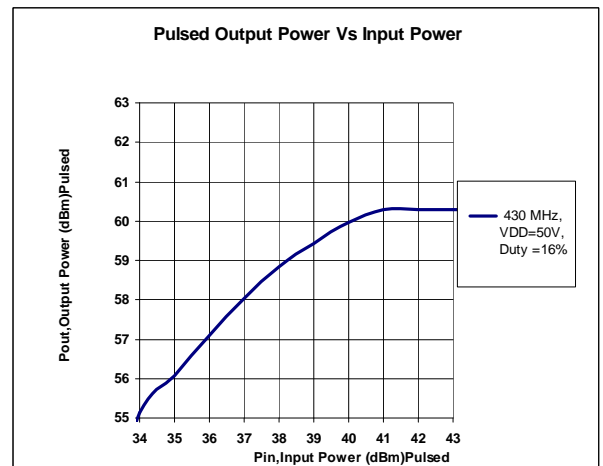

Fig.3 (a) Pulsed Output power Vs Input power

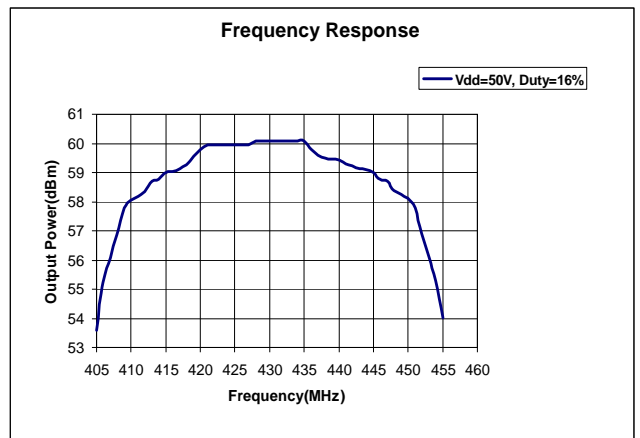

Fig. 3 (b) Frequency Response of Power amplifier

Fig.3(c) and 3(d) shows spectral domain response of a rectangular pulse for $1\mu\text{s}$ and $16\mu\text{s}$ pulse widths. Side lobe levels for both the cases is noted to be 13dB down with respect to carrier. Measured Second harmonics level is $<40\text{dBc}$.

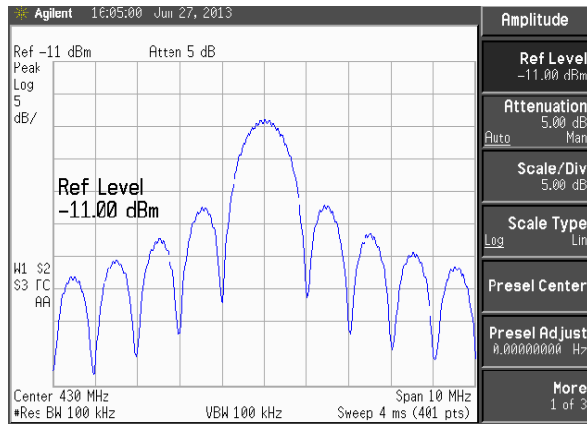

Fig. 3(C) Pulsed spectrum for 1 μsec pulse widths

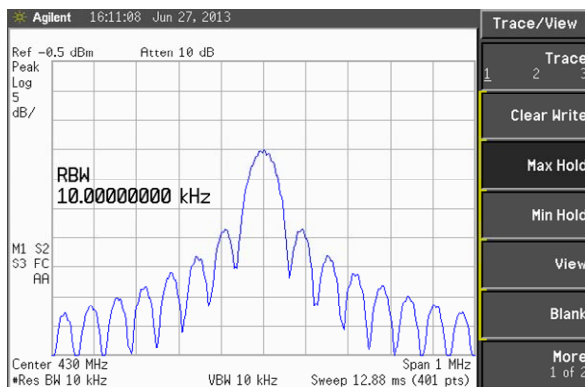

Fig. 3(d) Pulsed spectrum for 16 μsec pulse widths

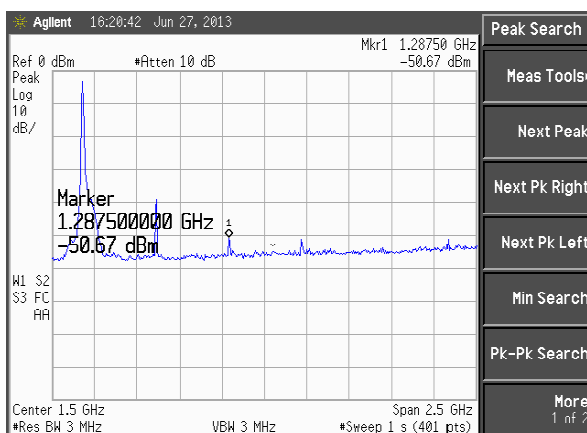

Fig. 3 (e) Harmonic response of the amplifier

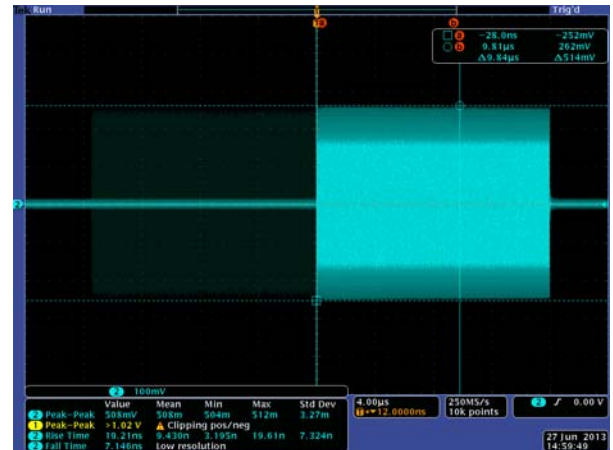

Fig .3(f) Time domain waveform

CONCLUSION

Broad band Power amplifier at 430 MHz is realized with an LDMOS push pull device to deliver 1000 Watts pulsed output power with an efficiency of 65% to 70% at 16% duty ratio. Broad band response is achieved, using co-axial transmission line impedance transformer. Copper spreader on aluminum heat sink ensured an efficient thermal management with junction temperature of 100°C at 16% duty and 1000W power output.

This SSPA is intended to be a part of the Transmit Receive Module for UHF radar system, operating at 430 MHz, for atmospheric wind profiling up to an altitude of 10-15 km with good spatial and temporal resolutions.

REFERENCES

- [1] "RF & Microwave Power amplifier design" by Andrei Grebnnikov .
- [2] "RF Circuit Design" by Chris Bowick.
- [3] Tsung-Chi Yu, Chaoen Wang, Lung-Hai Chang, Ming-Chyuan Lin, Meng-Shu Yeh, "The Development of High Power Solid-State Amplifier in NSRRC." IPAC10, Kyoto, Japan, pp. 3993-3995.
- [4] "Low-Cost 63% Efficient 2.5-kW UHF Power Amplifier for a Wind Profiler Radar" Brad Lindseth, Tom Kelly, William O.J. Brown1, Terry Hock, Stephen A. Cohn1, Zoya Popovic.
- [5] "Radio Frequency Transistor" by Norman Dye and H.Granberg.

BIO DATA OF AUTHORS



Shoma Kamle, received her M.Tech degree in Microwave Engineering from Rajiv Gandhi Technical University, M.P.in 2004.Presently working as Scientist/Engineer-‘SD’ in Radar Development Area/ISTRAC, Bangalore .Work Profile includes design, realization and development of RF and microwave sub systems in the area of phased array Radars.



S.N.V Satyanarayana received his B.Tech degree in Electronics and Communication Engineering from JNTU Ananthpur in1999. He has expertise on phased array radar systems including high power transmitter Receivers. Presently working as Scientist/Engineer-‘SE’ in Radar Development Area, ISTRAC, Bangalore.



R.Ranga Rao, Deputy Director ,Radar Development Area/ ISTRAC,Bangalore received his M.Tech degree in ??? Engineering from SVU,Tirupathi (A.P.)in year ???/ .His contribution includes development of Phased array Technology and Doppler Weather Radars in India. some of his leading works are MST radar at Gadanki(AP.),Doppler weather Radar@SDSC,SHAR ,DWR, Mumbai. Currently he is project director, Wind profiler, SDSC, SHAR.



Anitha Daniel received her B.E.(Hons) in ECE from Madurai Kamraj University in 1987,M.E. in ECE from I.I.S.C. in 1996.Since 1988 has been working in Radar Development Area/ISTRAC and has contributed to the development of RF Sub systems of Doppler weather Radars & Atmospheric Radars.